



NOM :

PROBLÈME 2 : CORRECTION DE PORTÉE DE PHARE



FEUILLE RÉPONSE – NOM :

Question 21

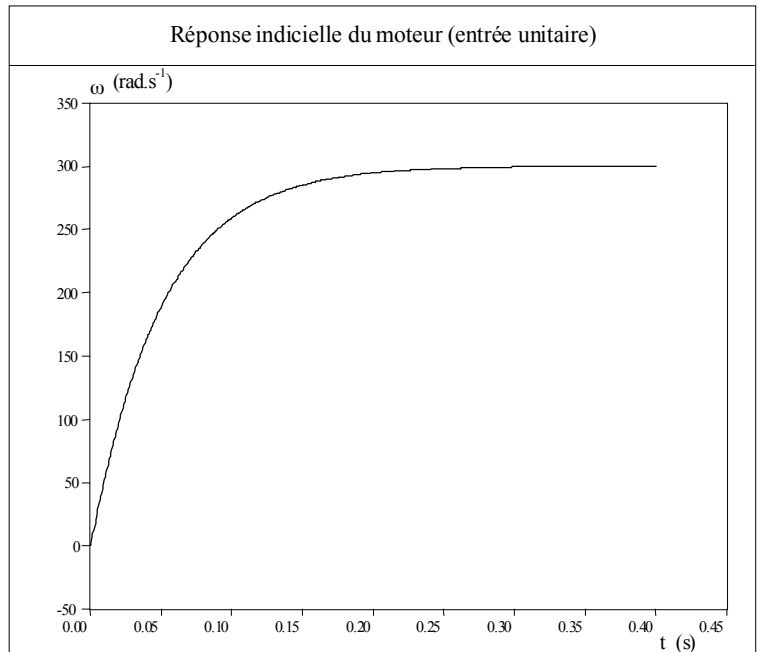

Question 44

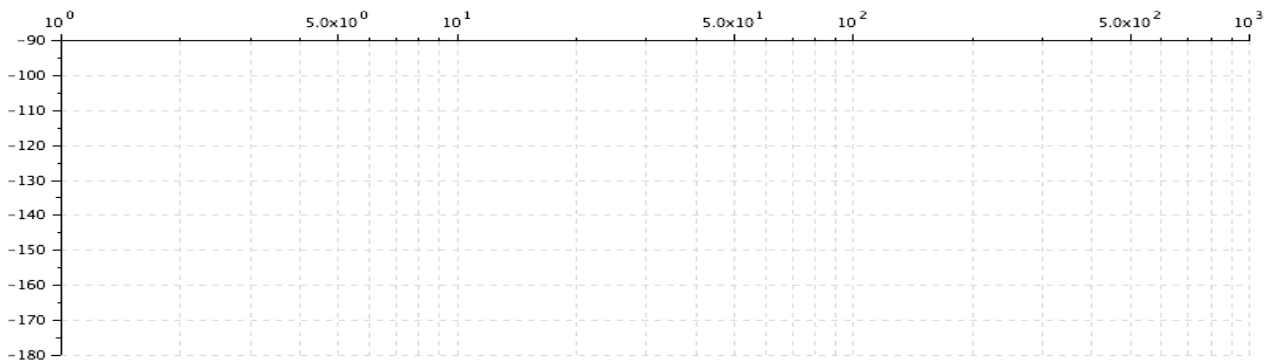
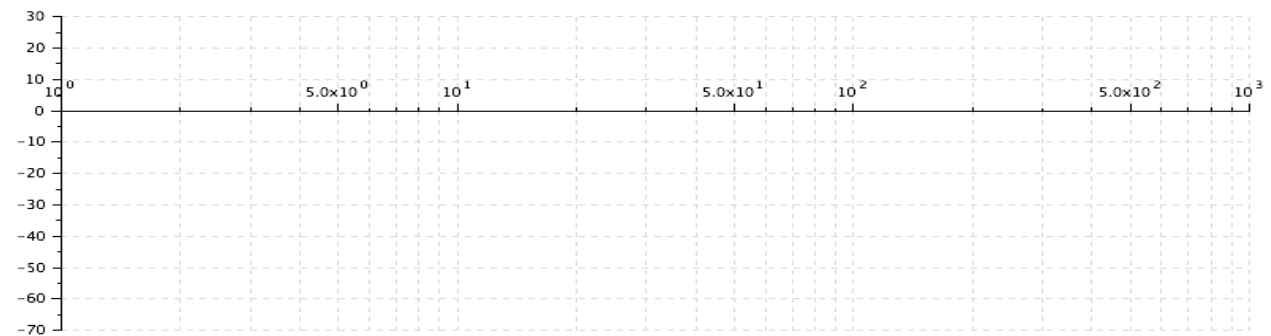

PROBLÈME 3

ROUE AUTONOME POUR FAUTEUIL ROULANT



Document réponse 3 : modélisation de l'asservissement en vitesse de rotation d'un moteur

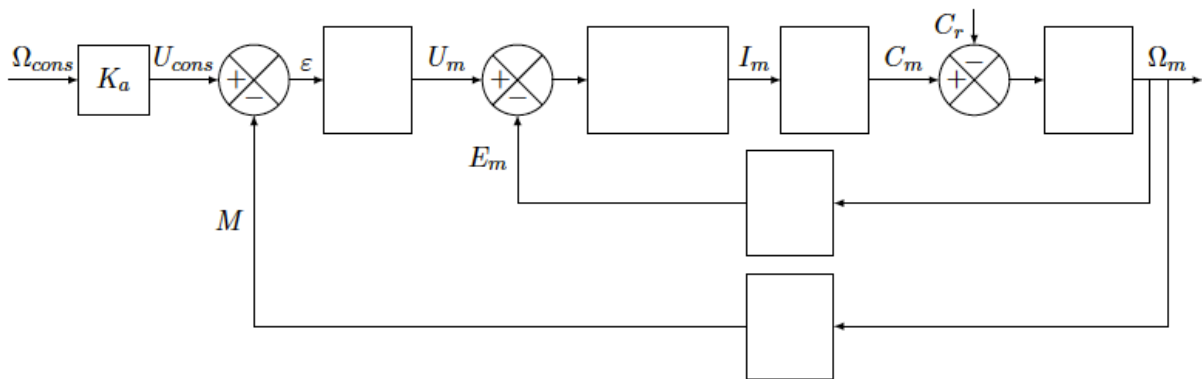

Document réponse 4 : tracé asymptotique des diagrammes de Bode de $FTBO(p)$ pour $K_p = 1$

